

Music takes us on a journey, whether listening to the maturity of Franz Schubert's sonatas, the "cool sound" created by Miles Davis, or the guitar virtuosity of Eric Clapton.

All expressed their emotions, identity and spirit by producing a unique sound that immersed their audience.

Our vision when developing the Luxman C-900u & M-900u was not only to produce superior audio quality, but also to design an amplifier capable of conveying the emotion of the original performance.

The C-900u & M-900u combine several of Luxman's key technologies, and are capable of integrating into any high-end audio system.

The result is an amplifier that delivers a first-class listening experience that offers more than just great sound.

Luxman places great importance on enhancing the emotions that you feel when listening to the highest quality sound. With the C-900u & M-900u once the volume is turned up you don't just hear the performance you feel it.

## C-900u CONTROL AMPLIFIER

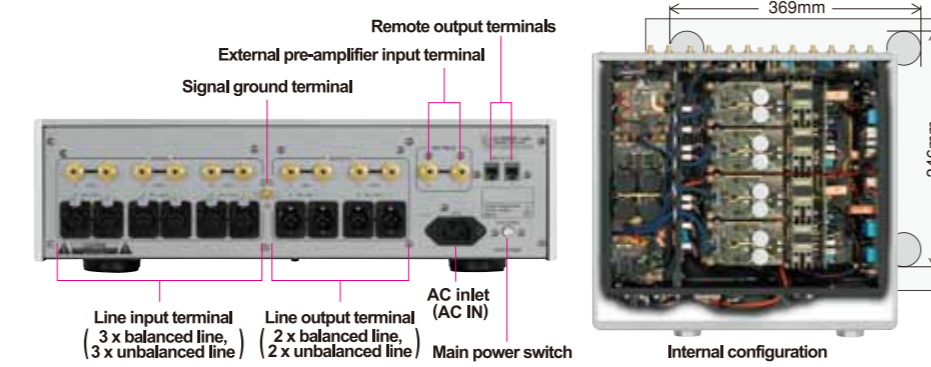
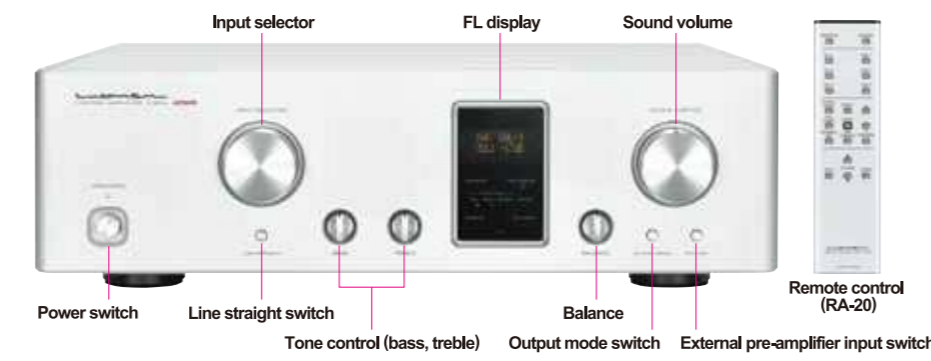

SPECIFICATIONS	
Input sensitivity/	Unbalanced 255mV/43kΩ
Input impedance	Balanced 255mV/86kΩ
Output/Input impedance	Unbalanced rating 1V/50, max. 11V
	Balanced rating 1V/180Ω, max. 22.5V
Frequency response	20Hz to 20kHz (+0, -0.1dB)
	5Hz to 120kHz (+0, -3.0dB)
Total harmonic distortion	Unbalanced 0.009% (20Hz to 20kHz)
	Balanced 0.005% (20Hz to 20kHz)
S/N ratio (BHF-A)	Unbalanced 123dB
	Balanced 126dB
Volume adjustment	New LECUA1000
Amplification circuit	ODNF 4.0
Max. change amount of tone control	BASS: ±8dB at 100kHz
	TREBLE: ±8dB at 10kHz
Remote control functions	<ul style="list-style-type: none"> <li>• Operation • Dimmer • Input selector</li> <li>• Output mode • Balanced phase selection</li> <li>• Channel preset • External pre-amplifier input</li> <li>• Line straight • Loudness • Volume up/down</li> <li>• Mute • Zoom</li> </ul>
Power consumption	42W
	2.2W (at standby)
External dimensions	440(W) x 130(H) x 430(D) mm
	front side knob of 17mm and rear side terminal of 14 mm included in depth
Net weight	19.7kg
Accessories	Remote control (RA-20)
	Power cable

## M-900u STEREO POWER AMPLIFIER

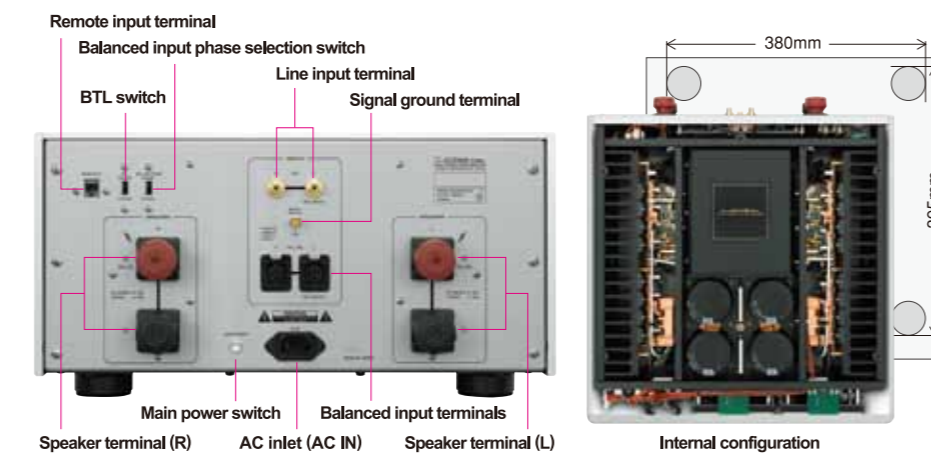
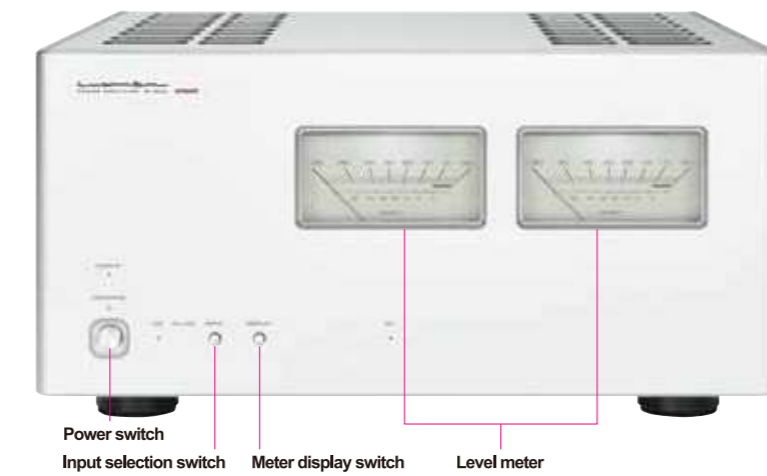

SPECIFICATIONS	
Rated output	150W + 150W (8Ω) at stereo
	300W + 300W (4Ω) at stereo
	600W (8Ω) at monaural
Instantaneous max. output	1,200W + 1,200W (1Ω) at stereo
	2,400W (2Ω) at monaural
Input sensitivity	1.24V/150W (8Ω)
	GAIN 29.0dB
Input impedance	Unbalanced 51 kΩ
	Balanced 34 kΩ
Frequency response	20Hz to 20kHz (+0, -0.1dB)
	1Hz to 130kHz (+0, -3.0 dB)
Total harmonic distortion rate	0.008% or less (1kHz/8Ω)
	0.1% or less (20Hz to 20kHz/8Ω)
S/N ratio (BHF-A)	117dB
Amplification circuit	ODNF 4.0
Output configuration	Bipolar 4-terminal push-pull x 2
Power transformer	EI type 1,250VA
Damping factor	710
Power consumption	540W
	280W (under no signal)
	1.0W (at standby)
External dimensions	440(W) x 224(H) x 485(D) mm
	front side knob of 2mm and rear side terminal of 38 mm included in depth
Net weight	48.0kg
Accessories	Dedicated remote cable
	Power cable
Speaker terminal	Width of part a: 14mm or less
Supported Y-ug terminal dimension	Width of part b: 7mm or more
	
	* Connection may not be performed depending on the shape of the Y-ug terminal.

## LUXMAN

IAG House, 13/14 Glebe Road, Huntingdon, Cambridgeshire, PE29 7DL, UK  
 Tel: +44 (0) 1480 452561 Fax: +44 (0) 1480 413103 <http://www.luxman.com>  
 ラクスマン株式会社 〒222-0033 神奈川県横浜市港北区新横浜1-3-1  
 Tel.045-470-6991 Fax.045-470-6997 [www.luxman.co.jp](http://www.luxman.co.jp)

IAG reserves the right to alter the design and specifications without notice. All rights reserved IAG Group Ltd. Luxman is a member of the International Audio Group. Code: LN14-LL001

### ⚠ Safety Cautions

To ensure correct use of this product, read the "Instruction Manual" prior to use. Failure to follow all safeguards can result in fire, electric shock, or other accidents.

\*Design and specifications are subject to change without notice.

2014.04-HB C900u M900u

# LUXMAN

CONTROL AMPLIFIER  
**C-900u**  
 STEREO POWER AMPLIFIER  
**M-900u**



“樂興の時” 始まる。

## M-900u

STEREO POWER AMPLIFIER

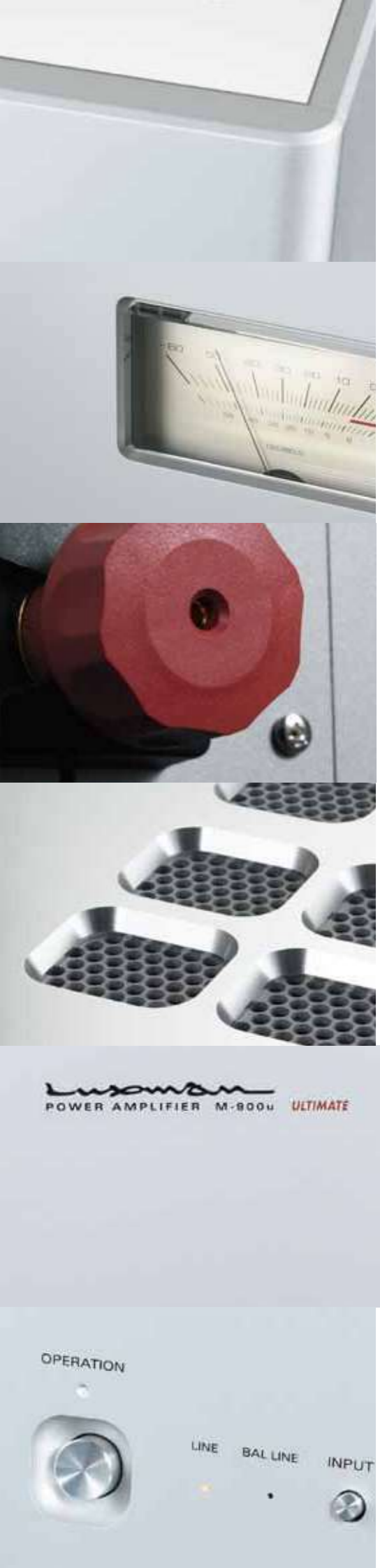



### New LECUA 1000 with fully balanced configuration, attenuator with discrete configured ODNF amplifier directly coupled

It can be said that the volume adjustment function is the core of a control amplifier. C-900u has been equipped with the high-precision attenuator that is electronically controlled and is switched by fixed resistance, which has been used in the Luxman's 80th anniversary flagship model, C-1000f, and also with the new LECUA 1000 that has been evolved from the amplification circuit integrated type, LECUA\* 1000. This type is extremely insensitive to external vibration and change in sound quality depending on sound volume positions, and also significantly excellent in durability. Increase in the number of steps from 72 to 88 allows more delicate sound volume to be adjustable without deterioration of sound quality within 0 to 87 dB. The completely balanced configured C-900u is equipped with 4 units of these new LECUA 1000s in parallel, which has achieved ideal balanced transmission. Because LECUA 1000 control is used for balance adjustment between right and left and level adjustment in the bi-amplifier output mode, there is no need for concern about the deterioration of sound quality. In addition, 3D layout is introduced in new LECUA 1000 to allow substrates to be placed in three dimensions, and the attenuator circuit is directly connected to the amplification circuit, which lead to minimize routes and improve efficiency. Only distortion components are fed back to the amplification circuit to maximize the advantage of the NFB (negative feedback), and the primary slew rate speed indicating the startup performance, ultra-wide bandwidth, and the latest version of the ODNF\* circuit that has achieved lower distortion are adopted. The ODNF circuit version 4.0 has acquired higher performance by making the first stage of the main amplifier 4 parallels, second stage Darlington connection, and the first stage of the error detection amplifier 3 parallels. Delicate sound expression can be achieved by improving the S/N performance with the amount of feedback minimized, especially improving distortion characteristics at high frequencies remarkably. We have paid special attention to the shape, weightiness, and texture of the volume knob and pursued natural high quality feeling for it because the knob has the most opportunities to be touched by the user.



#### Large-capacity high-inertia power supply circuit

The high-performance power supply circuit is configured, which consists of the CI type power transformer whose capacity is equivalent to the monaural power amplifier, B-1000f, for the voltage amplification stage under the philosophy of "Power Amplifier Driver" that drives the connected power amplifier precisely with sufficient power and a large-capacity block capacitor of 3,300µF x 4 units. The delicacy and powerfulness of sound signals are transmitted to the power amplifier with the support of the high-inertia power supply with remarkably high stability and almost no small voltage fluctuation.



#### Compatibility between user-friendliness and multifunction

C-900u has been equipped with user-friendliness, flexibility, and expandability in accordance with system environment as well as multifunction. The FL display with high visibility can usually display inputs and sound volume in a 2-stage fashion, and also zoom in the contents 4 times larger with the remote control operation. This unit is equipped with the bi-amplifier output mode in which a balanced circuit can be used as a 2-channel unbalanced output, the external pre-amplifier input that is useful for coexistence with an AV system, and the tone control electronically controlled for sound quality.



#### Highly rigid cabinet covered with blasted white

Highly rigid loopless chassis is used for the cabinet to eliminate ground loop that causes the deterioration of sound quality. Gradation cast-iron is selected for the legs to prevent resonance thanks to its characteristics of that the metallic structure becomes smaller from the center to the periphery of the leg. The legs eliminate adverse effects on the circuit parts caused by vibration from the power transformer or mounting surface. The blasted white exterior with no viewable structural screw adds a sense of high quality and dignified presence.



#### Aluminum remote control with moderate weightiness

The remote control to be frequently used is made of aluminum with moderate weightiness. The remote control allows the user to operate a wide variety of functions of C-900u in a centralized manner with remaining seated to perform sound volume adjustment as a matter of course, the loudness function that automatically provides optimal balance adjustment in an auditory sensation according to sound volume, balanced phase presetting that can be set for each input system, the display dimming function (brightness switching), the zoom function that can be operated from some distance, and more.

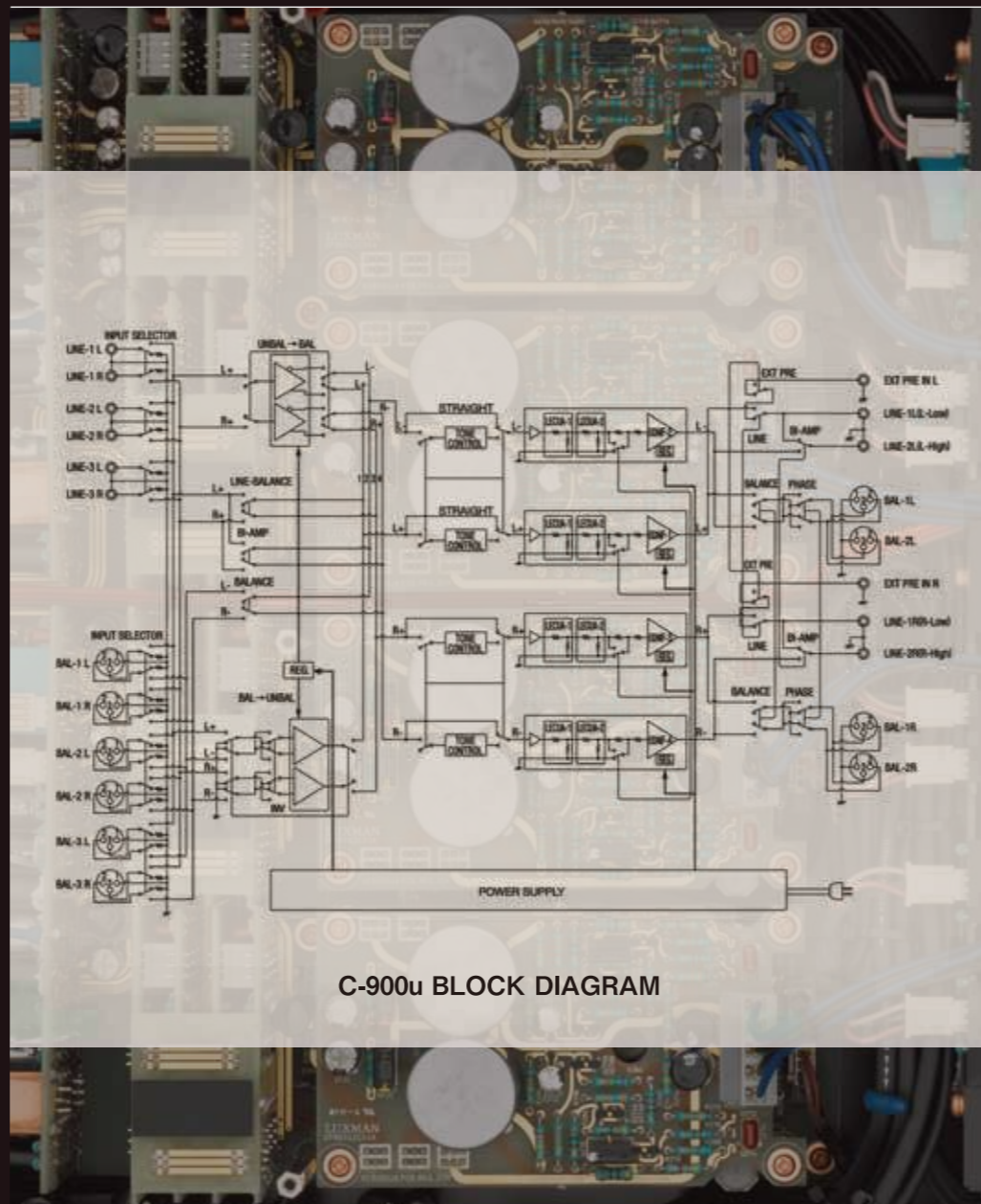

C-900u BLOCK DIAGRAM

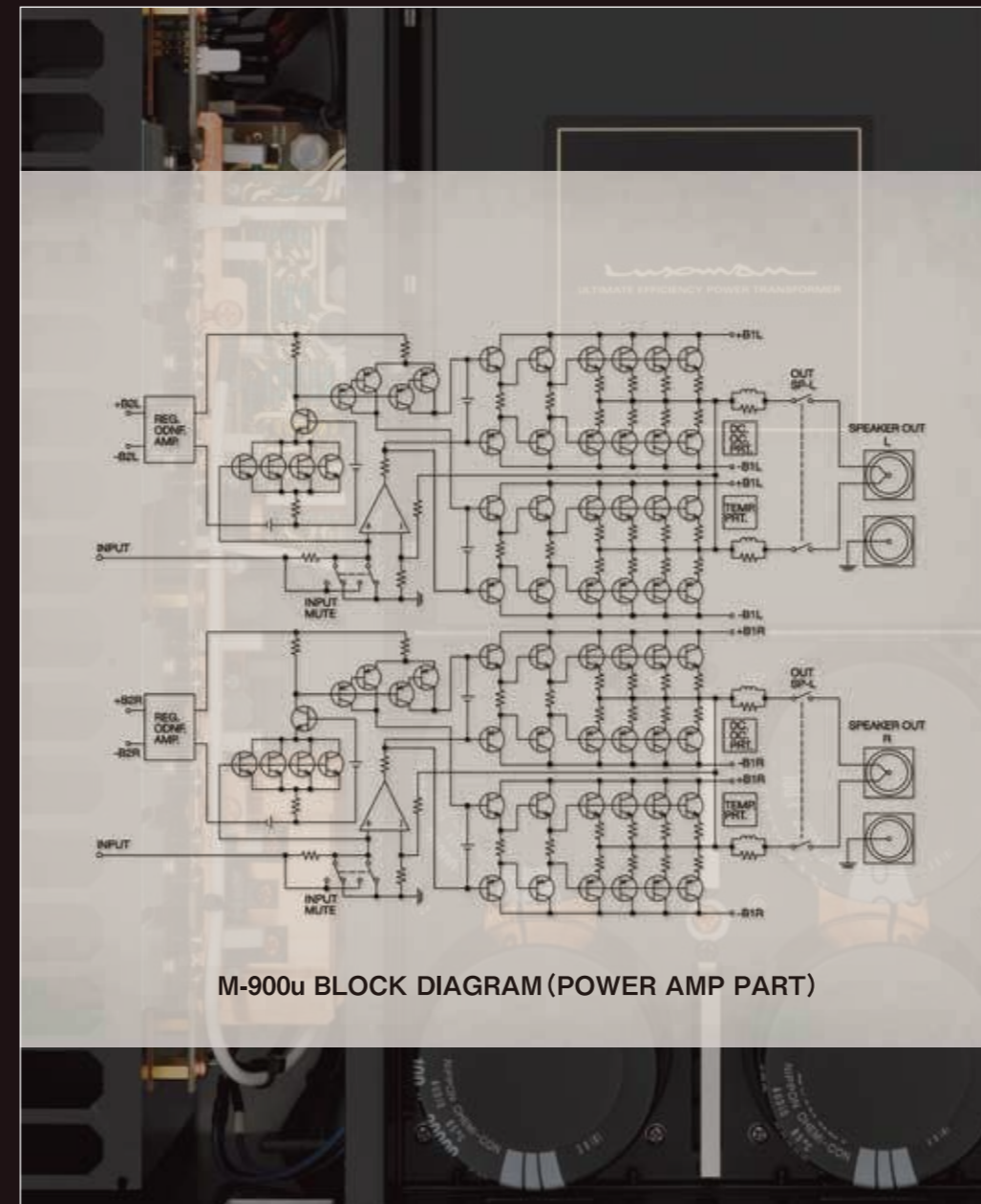

M-900u BLOCK DIAGRAM (POWER AMP PART)

### High power ODNF amplifier with 4x2 output structure, which has achieved overwhelming power linearity of up to 1,200W (1Ω)

The role of the power amplifier is to amplify sound signals from the control amplifier in faithful accordance with inputs and to vibrate the speaker units precisely. To perform these tasks, the great drivability and firm linearity of the output circuit are essential. M-900u has not only acquired sufficient rated output of 150 W + 150 W (8Ω), 300 W + 300 W (4Ω) but also achieved instantaneous maximum output of up to 1,200 W + 1,200 W (1Ω). Therefore, the unit can be ready with leeway for a sound source that requires high energy in a moment and drive speakers in any circumstances without being affected by change in speaker impedance. In addition, the BLT connection allows the user to use the unit as a monaural amplifier with the rated output of 600 W (8Ω). For the circuit configuration with this mighty power, 1 module of 3-stage Darlington and 4-parallel push-pull amplification circuit that is most excellent in sound quality according to our experiences of amplifier development for a long time and 4x2 output in which 2 modules are combined per a channel are used. The effect of the counter electromotive force from a speaker is suppressed by maintaining the damping factor to 710, and overwhelming power linearity to drive the speaker unit is achieved. The latest version, 4.0, of the ODNF circuit that performs feedback of only distortion components is introduced to the amplification circuit. Then, both the merits of NFB (negative feedback), i.e. low distortion and wide-band characteristics, and the features of a non-feedback amplifier, i.e. quick response and natural tone quality are provided. The ODNF circuit version 4.0 has the improved accuracy of detecting distortion with use of 3 parallels of the first stage of the error detection amplifier. The expressive power of silence has been improved and the sound emotion is finely and heavily expressed by minimizing the feedback amount, reducing the distortion at high frequencies or low sound volume, and reproducing minimal sound data precisely.



#### Large-capacity super-regulation power transformer

The high-performance EI type super-regulation transformer is placed on the power supply unit to support the high power of M-900u with the aim of eliminating the loss space, minimizing the capacity between lines, reinforcing the unifying force, stabilizing the magnetic field, and more by winding the flat-type copper coil tightly. The regulation performance that is not affected by any load fluctuation is achieved owing to the large capacity of as much as 1,250 VA. Power can be sufficiently supplied to fully drive the speaker unit.



#### Thoroughly low impedance transmission

To provide the power of the heavy-duty power supply circuit supplied from the large-capacity block capacitor of 20,000µFx4 to the amplification circuit instantaneously without any loss, the main electric current line between the power supply unit and output stage is directly connected by hardwiring using an extremely thick OFC bus bar. What is more, to transmit the powerful drive force generated by the large-scale output circuit without loss, the large-capacity speaker relay with low resistance in which 4 contacts are connected in parallel is equipped. The overwhelming value of the damping factor, that is 710, has been achieved.

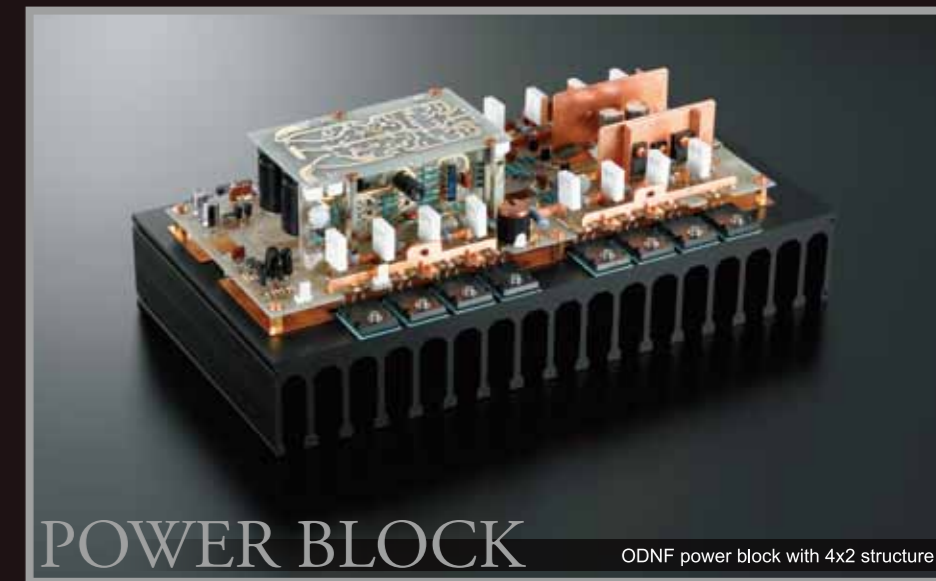

#### Large needle meter that shows how the sound really moves.

A large-scale needle-type meter is introduced to provide not only audible sensation but also physical sensation for the lively feeling of sound. The electric bulb color of the LED illumination is the result of our persistence in dignity and visibility. The meter is equipped with the ON/OFF switch for operation and the ON/OFF switch for illumination. For M-900u, up to 12 W of the output is operated with pure class A. In this case, the meter reads -10 dB or so, and the inclusion of almost all of the ordinary volume range balances between high power and dense sound quality with pure class A.



#### Highly rigid chassis structure supporting heavy parts

A stray current in the chassis generated by the ground loop may cause the deterioration of sound quality such as increase in impedance and magnetic field generation. To prevent this trouble, M-900u uses the loopless chassis that does not have a ground loop. The gradation cast-iron is used for the legs to shut off external vibrations and relieve internally generated vibrations. The chassis has a structure to hold heavy parts firmly and an appearance to show overwhelming presence and to be covered with blasted white neatly, which leads to the combination of strong and calm design.

## For uppermost tone quality — C-900u



### CONTROL AMPLIFIER C-900u

C-900u was newly created for the pursuit of the uppermost tone quality. The balanced amplification circuit having 4-module configuration in which the right/left and HOT/COLD of sound signals are set to be independent is introduced to suppress unnecessary noise generation. Combination of the evolved traditional ODNF circuit version 4.0 and powerful power supply unit has achieved high S/N performance sound quality without distortion. Luxman's original fixed resistance switching type attenuator, the latest version of "LEC UA 1000", is used for the volume adjustment mechanism that is the major key of the control amplifier. The number of contacts is set to 88 to allow the more precise volume adjustment to be performed. This product is appropriate for calling the modern control center because of its elegant design with user-friendliness, the tone control function, premium operation feeling, and more.



#### Original custom parts with most focusing on sound quality

The parts composing of circuits are important elements that determine the sound quality and tone quality of the amplifier, respectively. Luxman introduces a wide variety of carefully selected original custom parts such as transformers, capacitors, resistances, terminals, and even wiring materials. We guarantee that these parts feature high performance, and put our techniques and know-how that have been cumulated for a long time into the parts. Even for the selection of a part, we have listened with use of the part over and over, and achieved the sense of density that Luxman has sought for and fine and rich sound that does not cause fatigue.

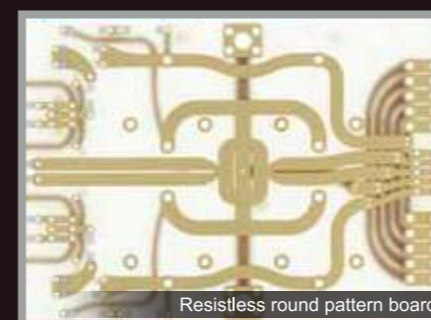

#### Peel coat board with use of extremely thick copper foil

Gold plating copper foil of 100µm in thickness is used for all the audio signal circuits, and the peel coat board with a special structure that has no resist layer on the signal line is used. Elimination of the effect from the capacitive component of the resist film reduces the pattern impedance and minimizes frequency deterioration. We exercise utmost caution to let fine sound signals flow smoothly with the round wiring pattern that draws a smooth curve with a width as constant as possible without acute angle bending.



#### Terminals to be connected, minimizing deterioration of sound quality

The input/output terminals play an important role and has a high risk of the deterioration of sound quality because signal communication with other audio components is performed via the terminals. C-900u/M-900u are equipped with the RCA terminals of high conductivity equivalent to copper and of hardness equivalent to brass, which is made of copper alloy that is a new material. Therefore, connection without loss in signal purity has been achieved.

## To bring out the best sound expression — M-900u

### STEREO POWER AMPLIFIER M-900u

The stereo power amplification, M-900u, has been created to bring out the best sound expression from the speaker system. The rich gradation sound quality has been achieved from deep bass sound to clear high tone with sufficient drive force acquired by connecting the 4-parallel push-pull structural output units in parallel. Luxman's original ODNF circuit that provides both a lively feeling and ultra-low distortion has been evolved to the latest version 4.0. The transparent large analog meter produces the enjoyment of listening to music with finesse, and the exterior design with blasted white finishing encloses high power gently. The BLT connection allows the user to use the unit as an ultra-high power monaural amplifier of 600W (8Ω).



\* LECUA is an abbreviation of Luxman Electric Controlled Ultimate Attenuator. \* ODNF is an abbreviation for "Only Distortion Negative Feedback".